

Rules of the Ultimate 20 Class Association

Effective September 19, 2008

These rules were ratified by the membership of the Ultimate 20 Class Association on September 1, 1998. They were amended on February 24, 1999, August 20, 1999; April 12, 2002; January 15, 2003; March 21, 2005; January 1, 2006, April 1, 2008 and on September 19, 2008.

Constitution

Article C-I. INTENT

1. These rules are intended to promote the Ultimate 20 as a strong one-design class as well as a recreational day sailor, cruiser and handicap racer. These rules shall preserve the important characteristics of this boat including ease of handling, low cost of ownership, simplicity, equality of performance, safety and comfort. Although they may serve as a model of rules for an international Ultimate 20 class, in their current form they shall govern the class in North America only.

Article C-II. JURISDICTION

1. The Ultimate 20 Class Association has jurisdiction over all Ultimate 20 class activities. The class Constitution and One-Design Class Rules are binding upon all members and fleets and govern all Ultimate 20 class races regardless of their sponsorship.

2. Prior to eliminating or deviating from any of the requirements set forth by this document, written permission must be obtained from the Ultimate 20 Class Association.

3. All disputes concerning the interpretation of the contents of this Constitution, Bylaws and One-Design Class Rules shall be resolved by the Executive Board of the Ultimate 20 Class Association, and all decisions of the Executive Board shall be considered final.

4. The Executive Board of the Ultimate 20 Class Association shall have the right to declare any boat which does not conform to the *spirit*, as well as the letter of these rules and regulations, ineligible to participate in class activities or to race as an Ultimate 20.

Article C-III. ORGANIZATION

1. The **name** of this organization is the Ultimate 20 Class Association. The Association is a nonprofit organization. It shall be the sole authority for the conduct and management of Ultimate 20 class events.

2. There shall be three classes of **membership**.

Active: An Active Member is a member in good standing of the Class Association, who may vote and hold office. An Active Member must be a registered owner or no less than 1/3rd part owner of an Ultimate 20. There can be only one Active Member per boat, i.e., one boat-one vote.

Associate: An Associate Member shall be a co-owner, family member of an Ultimate 20 owner, or non-owner of an Ultimate 20 who agrees to promote the interests of the Ultimate 20 Class Association. Associate Members may not vote or hold office in the Class Association.

Honorary: An Honorary Member is a person who has made a significant contribution to Ultimate 20 sailing or racing and promotion of the U20 Class. Honorary Members may not vote or hold office in the Class Association.

2.1. **Dues** for Active Members shall be \$55 per year. Dues for Associate Members shall be \$25 per year. Dues shall be payable on January 1 of each year. There shall be no dues for Honorary Members.

3. The **Executive Board** is composed of the class President, immediate Past-President, Vice-President, Secretary/Treasurer, Chief Measurer, and the Chairperson of each of the Districts. The Ultimate 20 designer, Jim Antrim, and one representative of the class builder, Ultimate Sailboats Inc. (USI), will serve as technical advisors to the Executive Board and may participate in its meetings, but will not have voting privileges.

4. Elected Officers and their duties shall be:

President: Presides at meetings; chairperson of the Executive Board; appoints committees; authorizes payment of all Class Association bills. Shall generally serve for two years.

Vice President: Officiates in the absence of President; performs other duties pertaining to such office as required by the President. Shall generally succeed to the Presidency.

Secretary/Treasurer: Keeps minutes of meetings; performs other duties required by the President; is responsible for the collection of annual dues, royalties and fees, and for the disbursement of funds; coordinates all financial matters for the class including budgeting and audit; annually prepares a balance sheet and income statement of the Class Association for the fiscal year.

Chief Measurer: Supervises the measurement procedure of the Class Association; is responsible for the training of Ultimate 20 measurers; serves as chairman of the Technical Committee.

5. **Other Officials** shall be appointed by the President, as follows:

District Chairpersons: Coordinate activities of each District, including District championships and other regattas; encourage racing, cruising and social activities within the district.

Executive Secretary: Handles day-to-day business of the Association, including mailings and publications.

6. The Ultimate 20 Class Association shall not be liable for any debts contracted by its officers, other officials or members other than expenditures authorized by the President and Secretary/Treasurer.

7. Geographic Subdivisions

7.1. **Districts** shall be defined by the Executive Board, encompassing contiguous geographic areas of North America. There are five Districts: Northeast, Southeast, Central, Northwest and Southwest.

7.2. **Fleets** shall be defined as groups of Ultimate 20s from one body of water, city, state, or contiguous group of states, but smaller than a District. A minimum of five boats shall be required to form a Fleet. Fleet Charters will be granted upon application to the Executive Board.

Article C-IV. ELECTION OF OFFICERS

1. The Executive Board shall appoint a nominating committee consisting of three Active Members of the Class Association in good standing. Nominations shall be published at least three weeks prior to the Annual Meeting. Any additional nominations from the membership must be received in writing (by mail, email or fax) by the Secretary/Treasurer at least two weeks prior to the Annual Meeting. Voting will occur by ballot, along with any other Amendments, to all Active Members of the Class, and the candidate(s) receiving the greatest number of votes for each elective office will be elected.

Article C-V. IMPEACHMENT AND TERMINATION OF MEMBERSHIP

1. An officer, District Chairperson, or Executive Secretary may be impeached, or a member expelled, by a 3/4th vote at an annual meeting or special meeting. A special meeting may be called within thirty days of presentation of suitable evidence that more than fifty percent of the Association members wish to institute impeachment.

Article C-VI. AMENDMENTS

1. Amendments to this Constitution or to the One-design Class Rules may be proposed by members of the Executive Board or by any Active Member.

2. An amendment shall be submitted in writing to the Executive Board for consideration and shall require for approval the affirmative vote of three-fourths of the members of the Board.

3. Amendments approved by the Executive Board as provided in Paragraph 2 of this Article shall then be submitted to the membership, and, to be adopted, must be approved by the vote of not less than two-thirds of the Active Members in good standing voting thereon. Notice of any such proposed amendment, together with a ballot to be used for the purpose of voting thereon, shall be sent by mail, email or fax to Active Members at their last known addresses as shown in the records of the Executive Secretary. Such notice shall specify the date, which shall be not less than 30 days from the date of mailing of such notice, on which the vote will be tallied, and ballots received subsequent to the date so specified may be disregarded.

Article C-VII. BYLAWS

1. Bylaws may be written by officers or proposed in writing by Active Members. They require approval by a majority of those voting at a National Meeting.

2. Bylaws may be amended by a majority vote at a National Meeting.

3. Bylaws may deal with issues effecting districts or fleets, and issues not otherwise addressed in this Constitution. Bylaws shall not deal with one-design or measurement issues, which must be added or amended as specified in Article VI of this Constitution.

Article C-VIII. ANNUAL MEETING

1. The Class Association Annual Meeting shall be held in the vicinity and during the time of the North American Championship.

2. A **quorum** shall be declared upon the attendance in person or by proxy of at least twenty-five percent of the Active Members. If a quorum exists at roll call, it exists throughout the meeting. If a quorum is not present, voting will be conducted by a mail ballot sent to all Active Members within two weeks after the Annual Meeting, and the outcome of such voting shall be determined by a majority of mail votes received at the Class Association office within 30 days of the date of mailing.

3. **Proxies** may assign all voting rights, including election of officers, to an Active Member who attends the meeting, or may designate how to vote for individual candidates and issues that have been published, along with a discussion of pros and cons, in advance of the meeting.

4. **Order of business** at the Annual Meeting:

1. Call to Order
2. Roll Call
3. Minutes of last meeting

4. Reports

5. Review of Charters
6. Review of Executive Board actions
7. Unfinished business
8. New Business
9. Nominating Committee report

10. Adjournment

Article C-IX. NORTH AMERICAN CHAMPIONSHIP

1. A North American Championship will be held every year. If possible, the venue will rotate among the Districts.

1.1. The North American Championship shall consist of a series of seven or more scheduled races. A minimum of one race must be completed. The winner shall be determined by the scoring system outlined in Appendix A of *The Racing Rules of Sailing*, using the low point system. If seven or more races are completed, there shall be a throw-out. A DSQ may not be thrown out.

1.2. An official Notice of Race will be sent to all Active and Associate Members in good standing at least one month prior to the North American Championship each year.

One-Design Rules

ARTICLE OD-I: *INTENT*

1. These rules are intended to maintain the one-design characteristics of the Ultimate 20. Any questions regarding the interpretation of these rules, and any questions not covered by these rules shall be resolved with the best interest of the class in mind, rather than any technical construction or misconstruction of drawings or text.
2. Except where variations are specifically permitted, boats of this class shall be alike in hull, deck, keel, rudder and spar construction, weight and weight distribution, sail plan and equipment.
3. All boats shall comply with the building specifications of Ultimate Sailboats Inc., and these one-design class rules. No alterations, modifications nor additions are permitted unless explicitly stated in these rules.

Article ODII: ELIGIBILITY FOR RACING IN CLASS SANCTIONED EVENTS

1. For any given boat, only one Active Member owner or bona fide co-owner or one Associate Member bona fide co-owner shall be eligible to enter a class-sanctioned event.
2. *HELMSPERSONS*: Eligibility shall vary depending upon whether a class sanctioned event is designated by the Executive Board as “closed” or “open.”

2.1. In **closed events**, which shall include the North American Championship and District Championships, a helmsperson must be one of the following: (a) an Active Member who is an Ultimate 20 owner or bona fide co-owner (as defined in Article C-III.2); (b) an Associate Member who is an Ultimate 20 bona fide co-owner (as defined in Article CIII.2); or (c) a member of a club which owns a fleet of Ultimate 20s and who is a paid participant in that club’s Ultimate 20 fleet program. Serving as helmsperson is defined as driving and handling the duties of skipper throughout all races of an event with the exception of temporary relief at the helm, which is not intended to provide a competitive advantage.

2.2. In **open events**, anyone may serve as helmsperson with the condition that an Active Member owner or co-owner of the boat or an Associate Member co-owner of the boat is on board the boat during racing.

3. *CREW*: There shall be no eligibility restrictions for crew members, other than those set forth below.

3.1. The total crew weight in sailing apparel shall not exceed 614 lbs. This weight limit may be waived for crews consisting exclusively of members of one family and in other individual cases, to be judged by the Executive Board, where there is no intent to gain a competitive advantage.

3.2. The minimum total persons on board during racing shall be two.

3.3. No changes may be made in the number of crew during any Ultimate 20 Class sanctioned regatta.

3.4. Substitution of crewmembers may be made only in case of illness or injury. Such substitution during a regatta requires the prior approval of all the other helmspersons.

3.5. When positioned in front of the forward stanchion, crew may not hike in such a way as to position their hips and torso any farther outboard than they could get if the lifeline were extended, at its normal height and distance from the gunwale, forward to the bow.

ARTICLE OD-III: SPECIFICATIONS

1. *GENERAL*: The hull, deck, interior, keel strut, keel bulb, rudder, tiller, bowsprit, mast, boom and standing rigging shall conform strictly to the builder's specifications and shall be manufactured from molds and dies by builders licensed by the copyright holder, Ultimate Sailboats Inc. Each boat will leave the factory matching class templates.

1.1 Tolerances in measurements and rules are to provide for minor and unavoidable construction variability, and may not be manipulated to optimize individual boat performance.

2. *WEIGHT*: The dry weight of the boat shall not be less than 1100 lbs. This weight shall include the keel, keel lifting crane assembly, bowsprit with its housing, jib roller furling drum, traveler, rudder bracket, companionway hatch covers, and foredeck hatch assembly if so equipped. The total weight of the boat, ready to race, shall not be less than 1210 lbs, including the above plus rudder and tiller assembly, mast, boom, all standing and running rigging, blocks and cleats, stanchions and lifelines, sheet bags, compass and running lights, but excluding sails, dock lines, fenders, anchor and rode, outboard motor and fuel, batteries, cushions, lifesaving equipment and other required equipment specified in rules OD-VII and OD-VIII.

2.1. Boats which do not meet the minimum weight requirement shall have weight added by permanently attaching lead weight to the mast strut. Removal of boat weight other than optional equipment is strictly prohibited.

3. *HULL*: The location of the chainplates, mast step, traveler, jib fairlead tracks, and spinnaker blocks shall be as specified by the builder, as shown in Figure 1, and may not be changed. Any and all repairs to the hull shall be done in a manner to return the hull to its original condition. Refairing of hull except in areas of repair is prohibited.

3.1. Each boat that races in a class-sanctioned event must display a current (dated) class association sticker on the transom, indicating that class association dues have been paid for the current calendar year.

4. *KEEL*: The keel fin and bulb shall be constructed and supplied by the builder.

4.1. The keel shall remain retractable, but shall be carried in a fixed, fully down and locked position while racing.

4.2 No changes may be made to the keel other than minor sanding or fairing within 5 mm radius from centerline at leading and trailing edges. The keel fin and bulb shall not be reshaped, faired nor sanded except to facilitate superficial repairs.

5. *RUDDER AND TILLER*: The rudder and tiller shall be constructed and supplied by the builder.

5.1. The rudder and tiller shall not be reshaped, faired nor sanded except to facilitate superficial repairs.

5.2. The rake of the rudder may be modified.

5.3. Tiller extension construction is optional. The maximum length (fully extended if so designed) shall be 48 inches.

6. *MAST AND BOOM*: The mast and boom shall be of aluminum alloy as supplied by the builder. Replacement spars must be obtained through the builder. The gooseneck must be permanently attached to the mast and located so that the distance from the base of the mast to the top of the boom is 32.5 inches \pm 0.5 inch as shown in Figure 2.

6.1 Bands of contrasting color shall be painted on the mast and boom as shown in Figure 2. While racing, the head and clew of the mainsail shall not overlap these bands.

7. *STANDING RIGGING*: Standing rigging shall be of steel construction. Upper and lower shrouds shall be 1x19 wire, 5/32 minimum up to 3/16 maximum diameter or DYFORM® 4mm diameter wire attached to the mast as provided by the builder. No rod rigging or line such as Kevlar may be used for standing rigging.

7.1. A single set of nonadjustable spreaders shall be attached as supplied by the builder. Their length, height and rake may not be altered.

7.2. Shrouds shall be attached to the chainplates at the locations shown in Figure 1.

7.3. Shrouds shall include tensioning devices, but shall not be adjusted while racing.

7.4. The length of the headstay assembly is optional, but its total length must be such that the rake of the mast (dimension **R** in Figure 3) is between 34' 9" and 35'.

8. *LIFELINES AND STANCHIONS*: Stanchions and lifelines as supplied and mounted by the builder are required. Attachment points for lifelines must be a minimum of 11 inches above the deck. Lifelines must be fairly taut while racing, defined as a maximum of two inches deflection from a straight line when measured at mid-span under no load.

9. *BOWSPRIT*: The bowsprit and its housing shall be as supplied by the builder and may not be modified.

9.1. The bowsprit shall be retractable to a point at least equal to the stem and shall not be capable of being extended beyond 71 inches forward of the stem. When the bowsprit is fully extended, the tack line shall be on the centerline of the hull extended.

9.2. The bowsprit shall be fully retracted (so that its tip does not extend beyond the stem) when the spinnaker is not flying, except when in the process of CONTINUOUS HOIST or immediately after dousing the spinnaker.

10. *SAILS*: All Ultimate 20 one-design class sails shall adhere to these one-design principles. Sails that do not meet class specifications will not be allowed to be used in class-sanctioned events.

10.1 To be eligible to race in U20 one-design events, all class sails must have a royalty tag affixed.

10.1.1 All Ullman U20 sails built before January 1, 2003, will not require a class royalty tag.

10.1.2 Class royalty tags are available from the class Secretary/Treasurer. The class royalty tags are \$10.00 per sail. Royalty tags must be placed within a 12-inch radius of the tack on each sail. All royalty tags must be sewn on each sail. Royalty tags cannot be transferred to another sail.

10.2 All sails shall be single ply except for reinforcements, constructional seams, tabling, reefing patches, batten pockets and repairs to damage.

10.3 Leech lines are permitted in all sails, and a luff line is permitted on the spinnaker.

10.4 MEASUREMENT: Sails shall be measured as specified by the International Sailing Federation (currently: ISAF Equipment Rules of Sailing 2005-2008 and Guide to Sail Measurement 2005-2008). These rules are available at <http://www.sailing.org/technical>.

10.4.1 **Mainsail**: The mainsail shall be made of woven Dacron with a minimum weight of 4.8 smoz (sailmaker's oz.). It shall be loose footed, i.e., attached to the boom only at its clew.

10.4.1.1. *Dimensions* Luff dimension (P) is from the bottom of the mainsail sheave to the top of the boom (27'4"). The foot dimension (E) is from the back of the mast to the black band (10'3"). The maximum leech girth and headboard width dimensions are shown in Figure 4. The maximum dimension shall be 5 5/8", including headboard width.

10.4.1.2. *Battens* There shall be five battens. The top three battens shall extend from leech to luff; the bottom two battens shall be partial, extending from the leech. The top batten shall not project higher on the leech than the 7/8 measurement point on the main. The maximum length of the partial battens shall be 60 inches. Battens may be tapered. Battens must be solid fiberglass; carbon and laminated battens are not permitted. Batten tension must not be adjusted while racing. Battens may not be altered or replaced on any given race day except in the event of accidental breakage.

10.4.1.3. *Reef Points* Usable reef points are required. The clew reef point shall be a minimum of 36 inches above the projected corner of the clew, excluding the outhaul slug.

10.4.1.4. *Sail Number and Class Logo* Each mainsail shall bear a U20 class logo as specified by the class association and an identifying sail number (usually, but not necessarily, the hull identification number). The Class

Logo shall be as shown in Figure 5. The class logo shall be 24" by 24". Artwork for the logo is available from the Class Association Secretary/Treasurer, or through the Technical Committee. The color of the logo and numbers is optional. Championship winners may be recognized by changing the color of the horizontal bar in the logo as follows:

- North American Championship: gold/yellow
- District Championship: red (or blue if the U20 is red)

10.4.2 Jib: The jib shall be made of woven Dacron with a minimum weight of 5.6 smoz. It shall be constructed to permit roller furling. It shall attach to the forestay with a zipper. The leech shall not be convex.

10.4.2.1. *Jib Battens* The jib may be fitted with a maximum of two vertical battens. The battens shall have one end placed on the leech. The battens may be permanently attached to the sail or may be removable. The batten material is unrestricted. The battens shall not prevent the jib from completely furling. Battens shall be a maximum of 30 inches long, minimum of 1/4 inch wide, and a maximum of 1 inch wide. Batten position on the leech shall be a maximum of 19 feet and a minimum of 6 feet from the clew.

10.4.2.2. *Dimensions* Maximum luff, leech and foot dimensions are shown in Figure 6. The half girth leech measurement is from the top forward corner of the head (including the zipper luff) to the projected corner of the clew. The 1/2 girth measurement is made with the zipper closed.

10.4.3 Class Asymmetrical Spinnaker: The class spinnaker shall be no lighter than 40 grams per square meter (.9 smoz). The body of the sail shall consist only of woven ply nylon, non-polyester, material. Only the official class asymmetrical spinnaker may be used in class-sanctioned events.

10.4.3.1. *Dimensions* Maximum luff, leech, foot and girth dimensions are shown in Figure 7. Minimum dimensions: No luff, leech, foot, or girth measurement may be less than 9 inches of the maximums shown. The spinnaker measurement will be as follows. Measure the luff, leech and foot from projected corner to make sure that the sail is within the dimensions. Next, fold the head and/or its projected corner to the projected corner of the luff, find the center of the fold, and this will be the luff mid-girth measurement point. Repeat the process folding the head to the clew to get the leech measurement point. Next, measure the distance between the luff fold point and the leech fold point. This will give you the mid-girth measurement. Now fold the head and/or its projected corner to the mid-girth measurement point on the luff. Find the center of the fold. Repeat the process folding the head and/or its projected corner to the mid-girth measurement point on the leech. The center of these two folds will be the 3/4 measurement point of the sail. When measuring a spinnaker, use sufficient tension to remove wrinkles and creases along the lines of measurement. Do not stretch the spinnaker cloth. Ease the tension on the foot/luff/leech cords.

10.5 WINDOWS: Transparent windows are permitted in all sails. If fitted, no dimension of any window shall exceed 60 inches and no edge shall be less than 4 inches from the nearest edge of the sail. Spinnaker windows shall not exceed 7.5 square feet in area.

10.6 RESTRICTIONS ON SAIL PURCHASES: Only one class mainsail, one class jib, one class spinnaker and their required royalty tags may be purchased in any calendar year. This limitation shall not be exceeded during the life of the boat for any reason except for un-repairable accidental damage.

10.7 REPLACEMENT: Any mainsail, jib or spinnaker may be replaced in the event of unrepairable accidental damage at any time by petition to the Chief Measurer with evidence of the accident.

10.8. MAXIMUM NUMBER OF SAILS: For any class sanctioned event, a maximum of three sails (one mainsail, one jib and one spinnaker) may be carried on board. No substitutions will be allowed except in the event of obviously un-repairable accidental damage. The restriction on substitutions shall apply for the entire duration of a regatta but not a series in which races are sailed a week or more apart.

10.9. USED SAILS: Any sail acquired in conjunction with the purchase of a used Ultimate 20 may be declared noncompetitive and replaced in accordance with section 10.6 "Restrictions on Sail Purchases".

ARTICLE OD-IV: MEASUREMENT AND INSPECTION

1. It is the responsibility of each helmsperson to ensure that his/her boat and sails are in compliance with these rules.
2. Sail measurement will be performed by the Chief Measurer or his/her designee at each North American Championship and other sanctioned events when appropriate. Sails which pass will be initialed by the measurer. Sails which fail to measure in may be re-cut and re-measured. Sails which do not bear the class royalty tag and measurers initials will not be permitted to race.
3. Boat inspection may be performed at each class sanctioned event, and may include, but not limited to, checking outboard motor and fuel or required alternate dead weight and ensuring compliance with safety rules, including lifeline specifications and required equipment.
4. Boats suspected of noncompliance may be challenged by any helmsperson and will be subject to inspection by the measurer for that event.
5. By participating in class sanctioned events, owners and helmspersons agree to permit class officers, measurers or their appointed representatives to board their boats for the purpose of inspecting, measuring and enforcing class rules.

ARTICLE OD-V: OPTIONS, ALTERATIONS AND REPLACEMENTS

1. Alterations to the boat and hardware that meet the intent of Article OD-I and do not materially effect sailing performance are allowed. Examples include: retractable rudders (not to be retracted while racing), and vents or alterations in interior outfitting which do not reduce hull weight or alter hull balance.

2. Blocks, eyes, cleats and fairleads associated with the mainsheet, jib sheets, spinnaker sheets, spinnaker halyard, spinnaker tack line, and jib furling arrangements may be replaced, but the location of the fittings shall not be changed. Additional cleats and blocks may be added. The spinnaker halyard block and the spinnaker halyard exit block may be replaced with a single halyard exit block.
3. The configurations of the mainsail outhaul, boomvang and cunningham are optional.
4. Solid boomvangs and devices such as the BoomKicker® are allowed.
5. The jib sheet configuration between the fairlead and the clew is optional, but the sheet must lead through a block on the track location shown in Figure 1.
6. Barber haulers and twingers are permitted, but their construction must not violate the watertight integrity of the deck, i.e., they shall not be led through the deck or cockpit sides.
7. The purchase of the mainsheet is optional.
8. The location of the mainsheet blocks may be moved to either one or both of the boom eyes to allow the blocks to be hung from lanyards.
9. The cockpit floor swivel base for the mainsheet block and cleat may be located aft or forward of the traveler, but must be in the centerline of the hull and no more than 8 inches from the traveler.
10. The jib sheets and spinnaker sheets may be continuous.
11. The length and diameter of sheets and control lines is optional.
12. The following devices and electronic instruments are permitted while racing:
 - Mechanical masthead wind direction sensing devices such as the Windex®.
 - Devices to measure speed, distance and water depth.
 - All types of compasses, including the Tacktick® and other electronic compasses.
 - VHF radios.
 - GPS may be used only on long distance races (over 12 nautical miles long) or races that will continue after dusk.
13. A kelp stick may be allowed in sanctioned events by 3/4 majority vote of helmspersons at that event.
14. Lifelines may be replaced with line of equal or greater strength.
15. Check stays are allowed as supplied by the Builder and installed per the Builder specifications.

ARTICLE OD-VI: PROHIBITIONS

1. The following are prohibited:
 - Hiking straps, trapezes and all other contrivances used to facilitate hiking.
 - Alterations that violate the watertight integrity of the forward V berth compartment or the rear stowage compartment.
 - Electronic wind sensing devices and computers which use electronically gathered wind and bearing data to derive true wind velocity and direction and calculate VMG may not be used during races.
 - Hydraulic adjustments of any type (e.g., boomvang).
 - Forestay length adjustments while racing.
 - Backstays of any type.
 - Mainsail, jib or spinnaker shape or trim controls other than those specifically mentioned in these rules.

- Through-deck spinnaker launchers (other than the companionway hatch provided by the builder).
- Mast bending devices such as struts, rams or midstays.
- Coring, drilling out, rebuilding, replacing materials, or grinding of hull, foils or spars.
- Relocating standard equipment to improve pitching or heeling moment.
- Stripping interior or removal of equipment such as running lights and foredeck hatch to reduce weight.

ARTICLE OD-VII: SAFETY RULES AND EQUIPMENT

1. All boats in all sanctioned events shall comply with safety regulations of the U.S. Coast Guard or other governing body of the area in which the event is sailed. In addition, all US SAILING rules shall be complied with except in instances of conflict, in which case the Ultimate 20 Class Rules shall take precedence.

2. The following items of safety equipment are required:

- Personal Flotation Devices: one type I, II or III for each person on board, plus one type IV or V throwable device.
- Whistle or horn.
- At least one type B1 fire extinguisher.
- Paddle not less than 48 inches long.
- Anchor, with or without chain, of combined minimum weight of 5 lbs, with a minimum of 100 ft. of 3/8" non-floating rode. The anchor line shall also serve as a tow line.
- Bailing device: 2 gallon bucket and/or manual pump.
- Marine first-aid kit.

3. All Ultimate 20 sailors are strongly encouraged to wear personal flotation devices while on the water.

ARTICLE OD-VIII: OTHER REQUIRED EQUIPMENT WHILE RACING

1. All standard equipment supplied with the Ultimate 20 including the keel crane with post, floorboards, cabin hatch cover and door, which may be stowed in the cabin. Floorboards may be also be constructed of 1/2" plywood, 1/2" Starboard or Dri-Dek all measuring a minimum of 32"x32".

2. Either:

A. Outboard motor, minimum of 2.0 hp, motor bracket and a minimum of 1/2 gallon of motor fuel in a suitable container as required by law or USCG regulations ... or

B. Dead weight, i.e., something that serves no other purpose, of 30 lbs, secured to the interior mast support.

3. Two fenders.

4. One marine compass of any type.

5. Appropriate dock lines.

ARTICLE OD-IX: ADVERTISING

1. Advertising shall follow the rules set forth by US SAILING.

Ultimate 20

Deck Locations

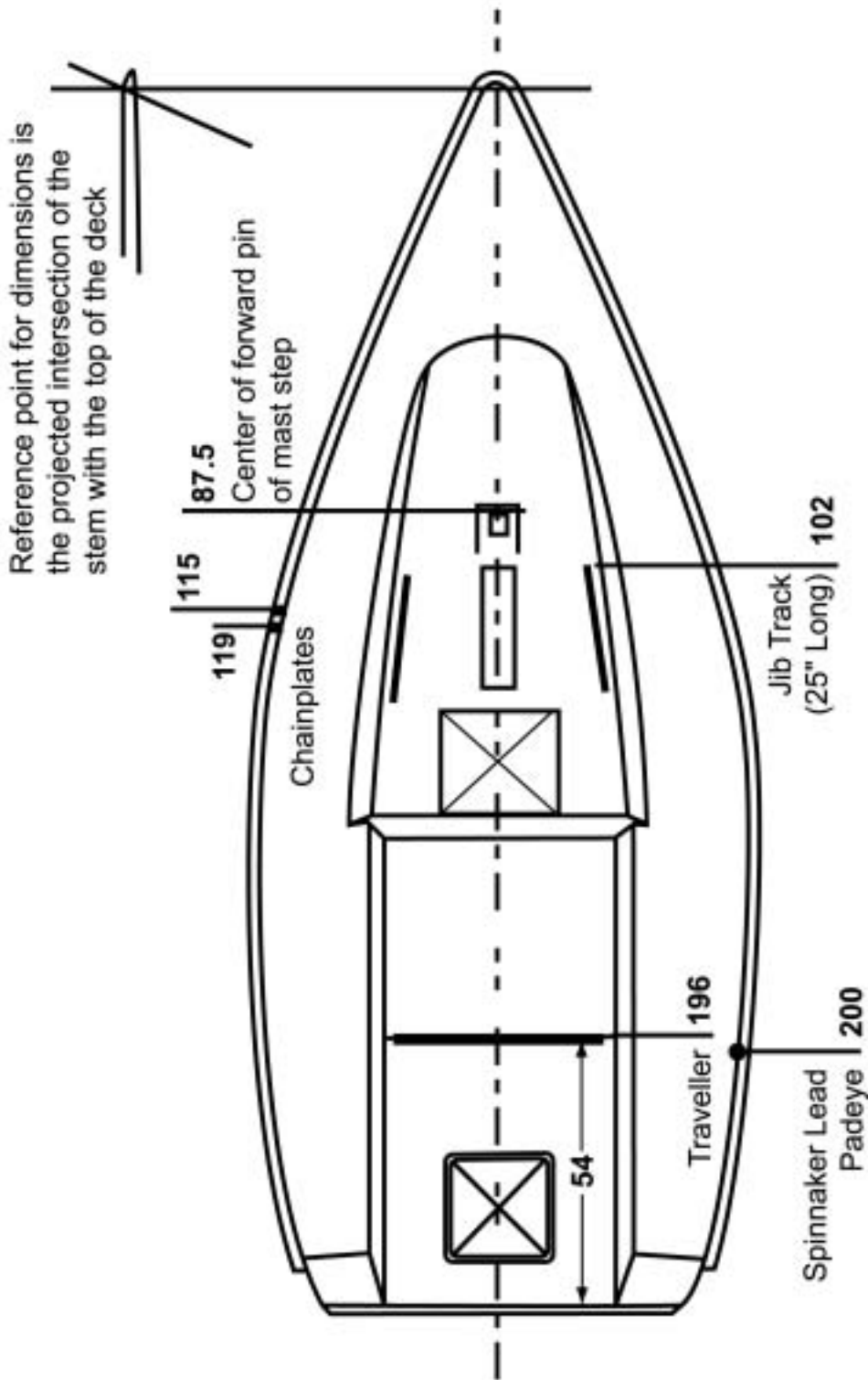

Notes:

- 1 All measurements are in inches
- 2 All dimensions are measured on the shortest line between the location and the reference point in the centerline of the bow
- 3 Tolerance for mast step and chainplates = $\pm 0.5"$
Tolerance for other locations = $\pm 1.5"$

Figure 1

Ultimate 20

Gooseneck, Mast, and Boom Bands

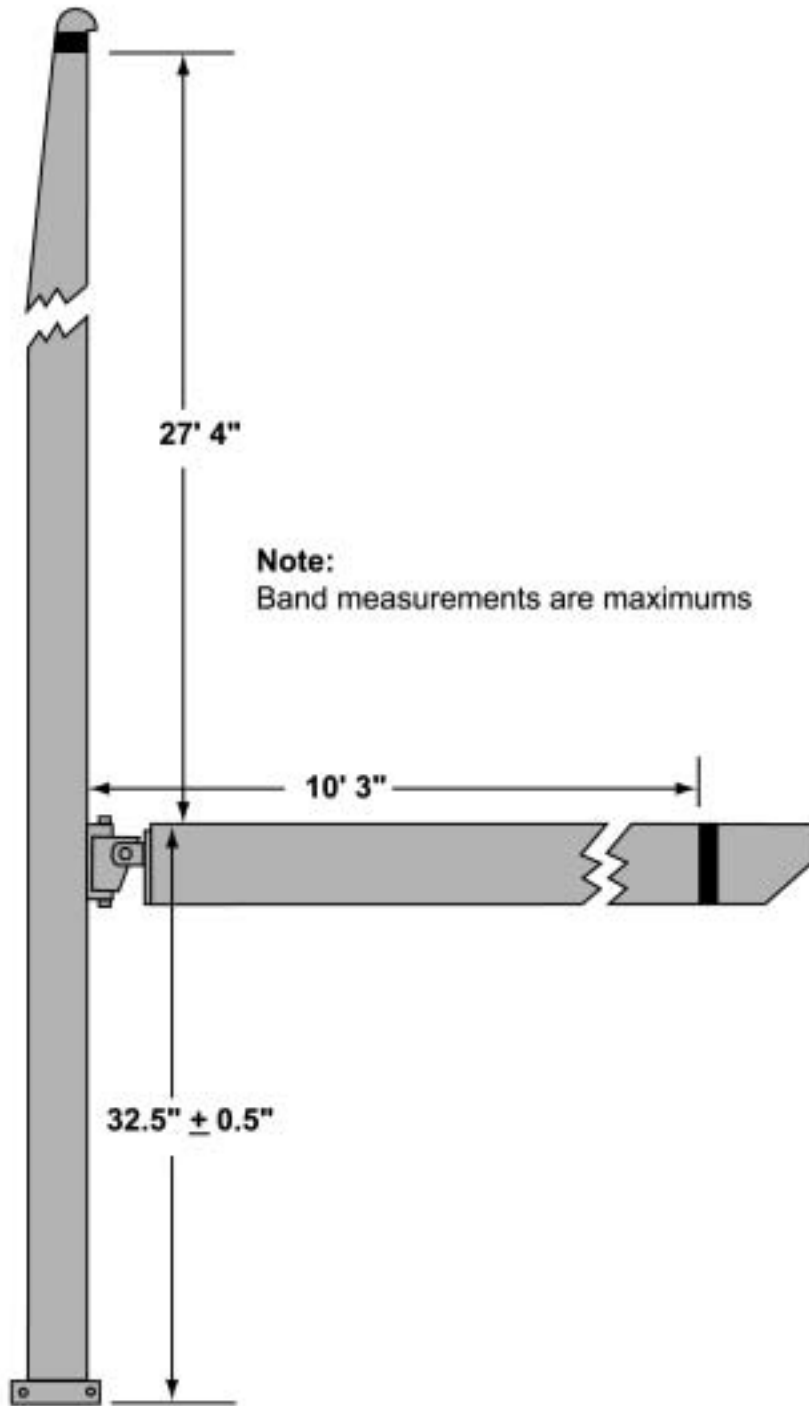

Figure 2

Ultimate 20

Mast rake measurement

Notes:

1 R = distance from bottom of top shoulder of main halyard nicopress sleeve with sleeve gently wedged in mast-top sheave

2 Measure with cap shroud tensioned of 300 lbs (LOOS model 591 guage) and one lower shroud tensioned just enough to straighten the mast laterally

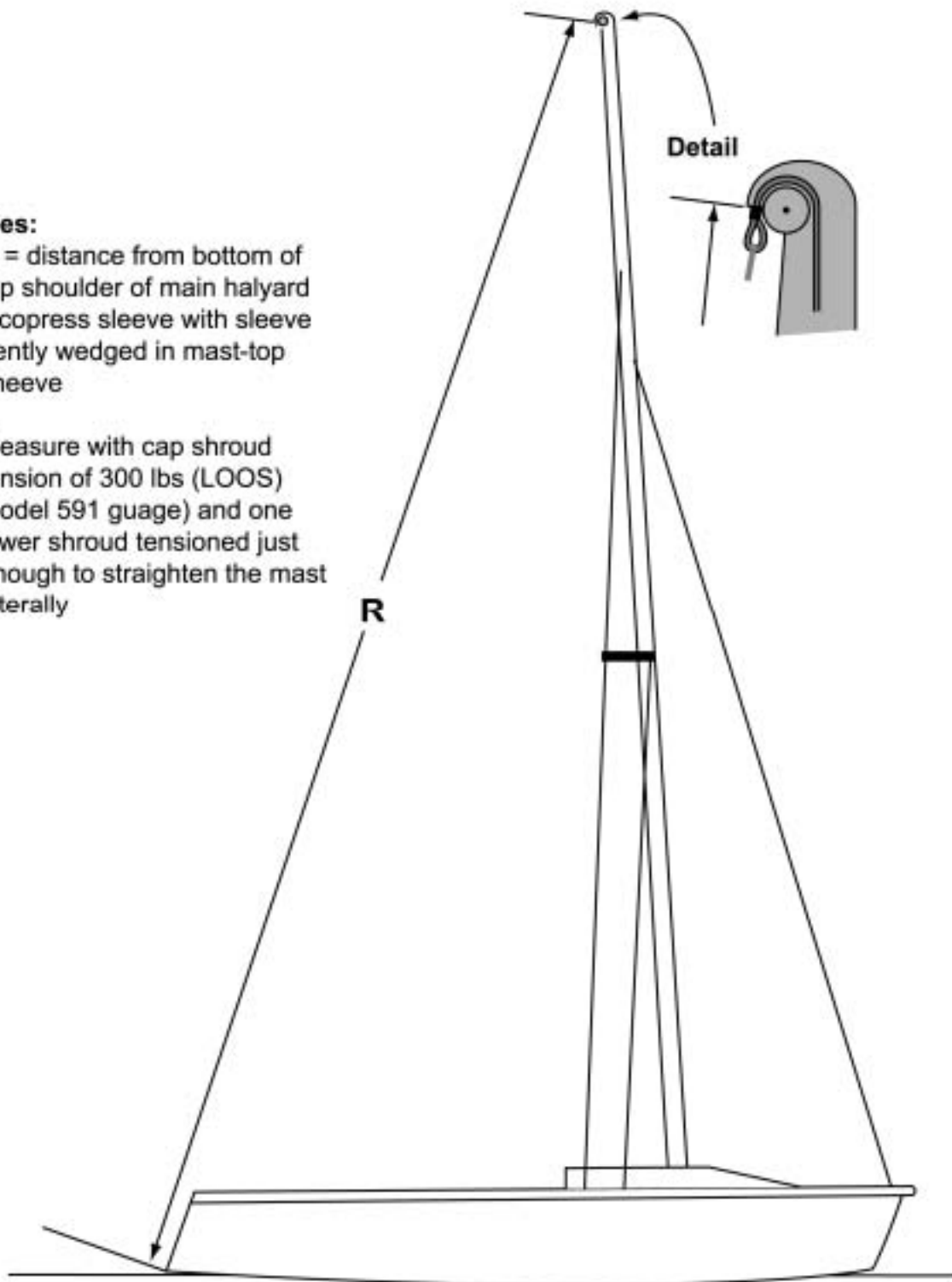

Figure 3

Ultimate 20

Class Main

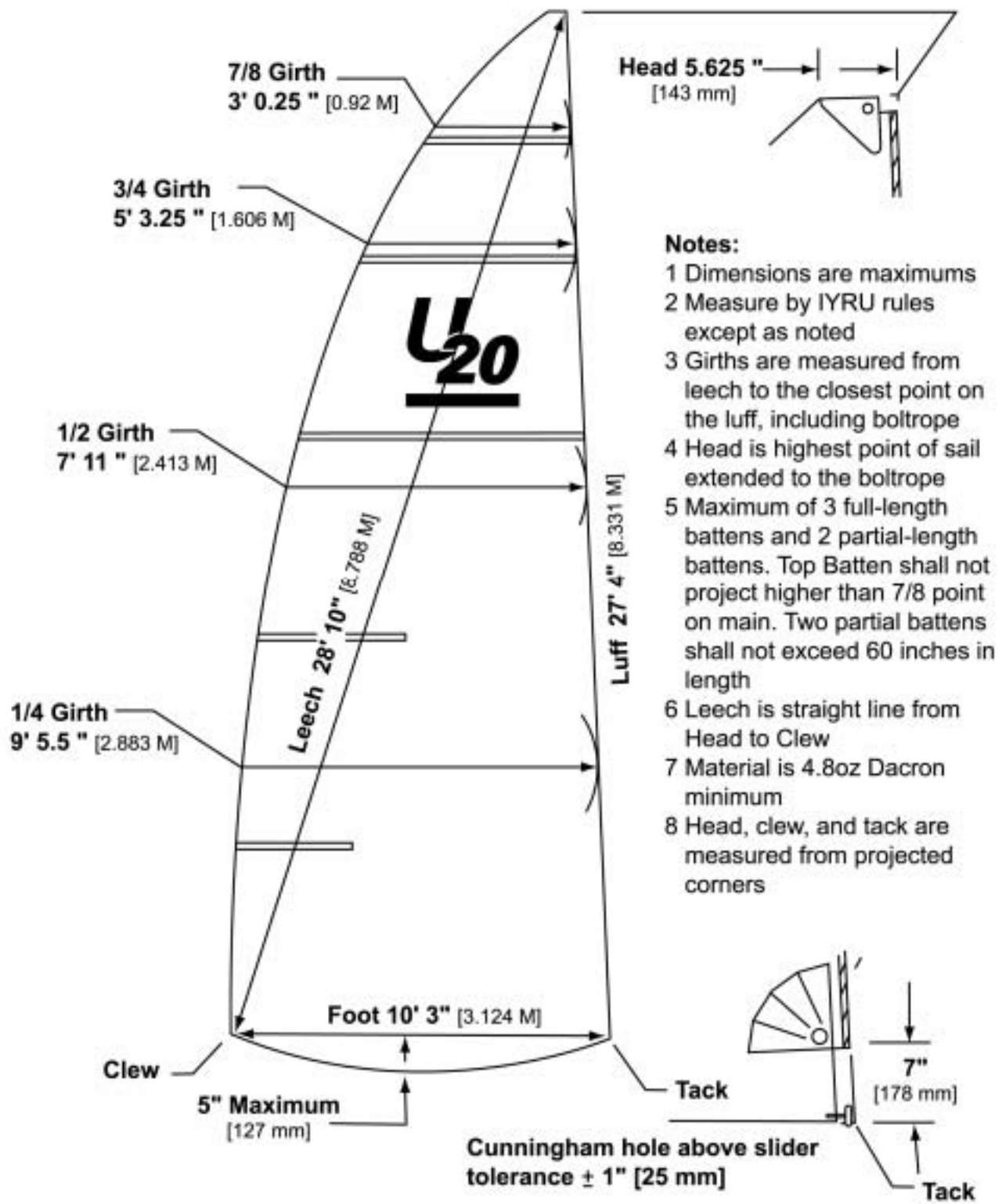

Figure 4

Ultimate 20
Class Association Logo



Note:
Artwork for Ultimate 20 Class
Association logo is available
from Class Officers or via the
Class Association web site

Figure 5

Ultimate 20

Class Jib

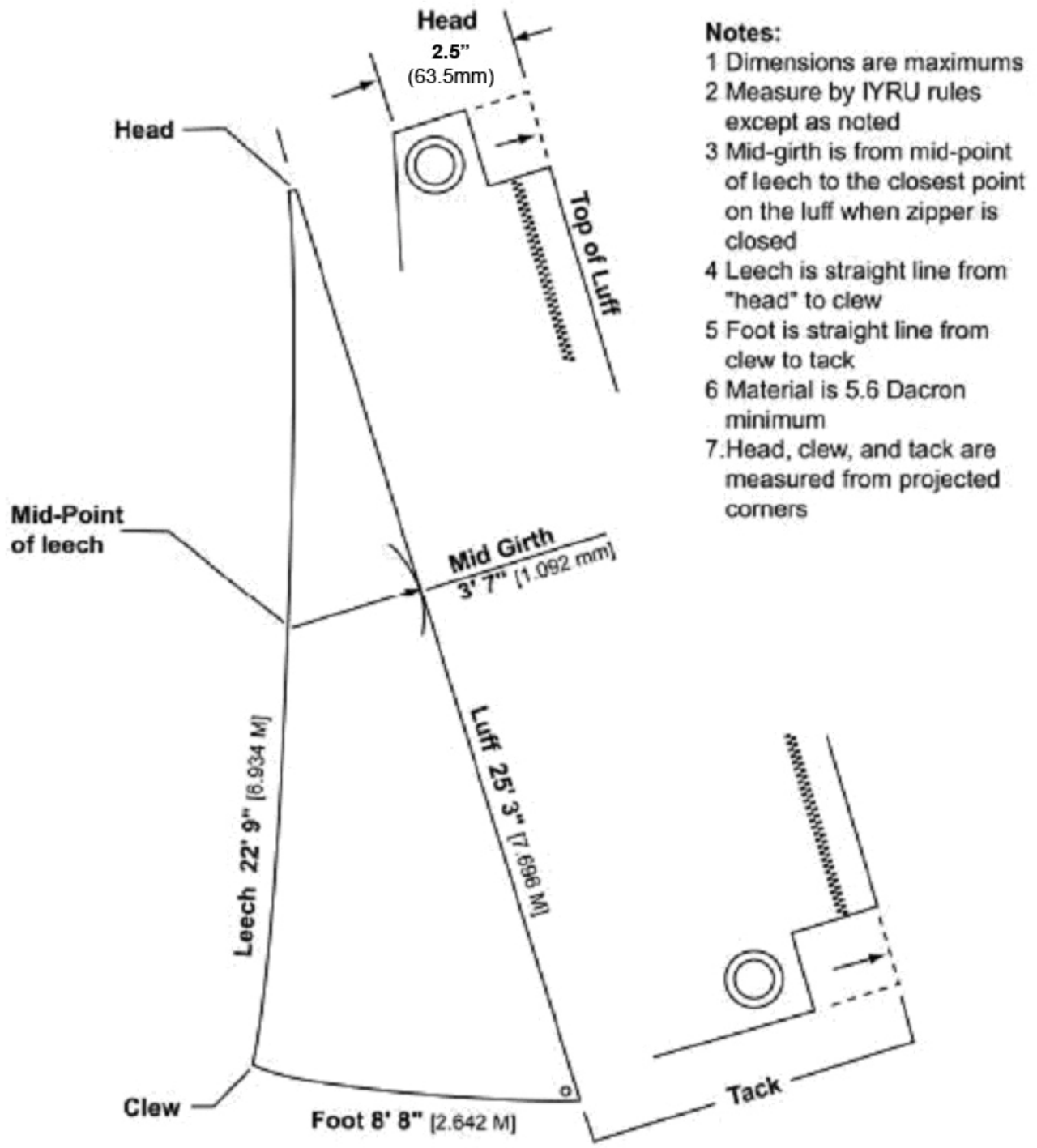

Figure 6

Ultimate 20

Class Spinnaker

I	26' 1"	[7.950 M]
J	6' 11.64"	[2.124 M]
P	27' 3.96"	[8.330 M]
E	10' 3"	[3.124 M]
ISP	27' 7"	[8.407 M]
JSP	12' 9.5"	[3.899 M]

Notes:

- 1 Dimensions are maximums
- 2 Measure by IYRU rules except as noted
- 3 Mid-girth is from mid-point of leech to the mid-point of luff
- 4 Material is minimum 40 gram/sqM nylon
- 5 Maximum dimensions are shown
Minimum dimensions may be up to 9" less than maximum
- 6 Head, clew, and tack are measured from projected corners

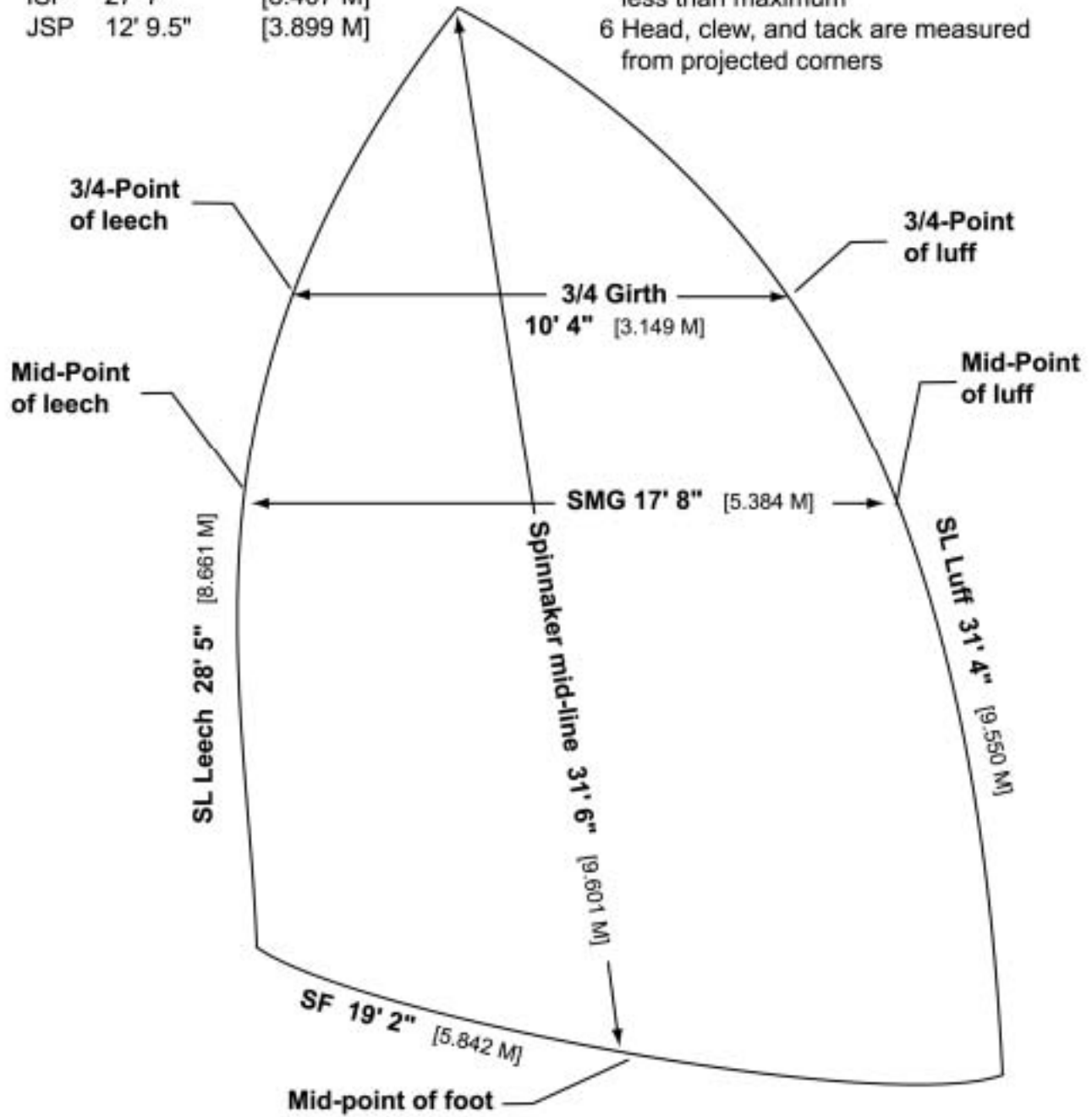

Figure 7